

## 1. OVERVIEW

The PythPits-series SMH-01B11 is a thermopile-type infrared array sensor module that features an 8×8 array of sensor elements to detect and convert the infrared energy within an area to a signal for output.

It is equipped with a Si-lens optical system, and features an MCU with built-in A/D converter that generates digital output, on an I<sup>2</sup>C interface, of both the converted emission temperature of each sensor element and the ambient temperature from a temperature sensor mounted on the sensor chip.

## 2. FEATURES

- 8×8 structure, 64-element array
- Si lens optical system, approximately 35° total field-of-view angle (between peak value of elements on both sides)
- Gain switching for measurement extension up to 250°C using variable-gain preamplifier (25°C ambient temperature environment)
- Built-in auto range function automatically adjusts the gain to match the temperature within the area
- Switchable frame measurement speed: 4, 2, 1 fps
- Switchable voltage output and emission temperature conversion output
- Changeable data readout order: top/bottom reversal and left/right reversal to support horizontal/vertical rotation
- SMBUS standard PEC code support
- Emission temperature resolution: ±1.5°C
- Supply voltage: 5V ± 5%
- Current consumption: 8.8 mA (typ.)

## 3. BLOCK DIAGRAM

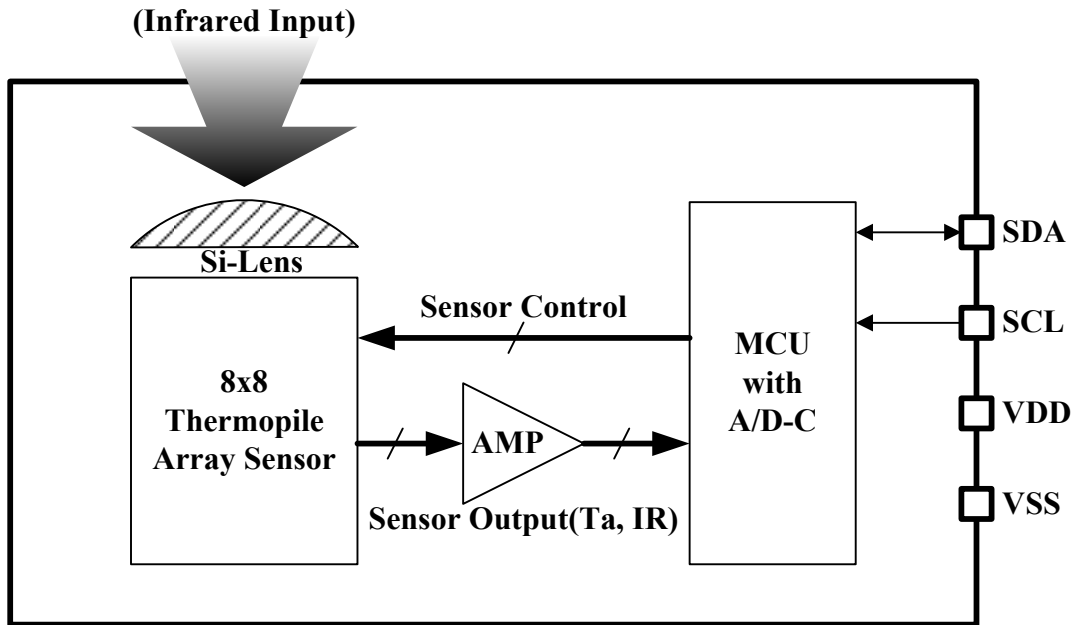
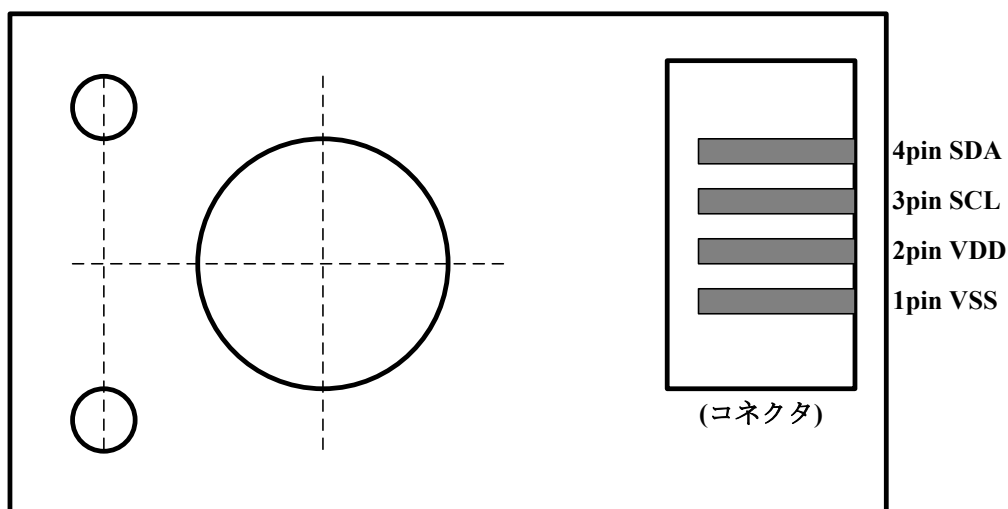

Figure 3-1. Block Diagram

## 4. PIN LAYOUT



Connector: S4B-ZR-SM4A

Top view

Figure 4-1. Pin layout diagram

## 5. PIN DESCRIPTION

No.	Name	I/O	Function
1	VSS	-	Ground pin
2	VDD	-	Supply pin
3	SCL	I/O	I2C interface clock input/output pin*1
4	SDA	I/O	I2C interface data input/output pin

\*1: SCL is an output during clock stretching.

## 6. ABSOLUTE MAXIMUM RATINGS

Parameter	Symbol	Conditions	Rating	Unit	Notes
Supply voltage range	$V_{DD}$	Between VDD - VSS	-0.3 to 6.0	V	*1
Input voltage range	$V_{IN}$	Between input - VSS	-0.3 to VDD+0.3	V	*1, *2
Output voltage range	$V_{IN}$	Between output - VSS	-0.3 to VDD+0.3	V	*1, *2
Maximum sink current	$I_{SNK}$	Output pin = Low	10	mA	
Storage temperature	$T_{STG}$		-40 to 100	°C	

\*1: Absolute maximum ratings are values not to be exceeded, not even momentarily. If a rating is exceeded, there is a risk of deterioration in characteristics and decrease in reliability.

\*2: VDD value is the operating voltage rating of the VDD pin in the recommended operating conditions.

## 7. RECOMMENDED OPERATING CONDITIONS

Parameter	Symbol	Conditions	MIN	TYP	MAX	Unit
Supply voltage	$V_{DD}$		4.75	5.00	5.25	V
Operating temperature	$T_a$	No condensation <sup>*1</sup>	5	25	45	°C

\*1: Operation is supported until the upper storage temperature from -20°C, but emission temperature correction cannot be confirmed if these ratings are exceeded.

## 8. ELECTRICAL CHARACTERISTICS

### 8.1. DC Characteristics

(Reference circuit under recommended operating conditions, unless otherwise noted)

Parameter	Symbol	Conditions	MIN	TYP	MAX	Unit
Current consumption	$I_{DD}$	VDD=5.25V		8.8	12.0	mA
High-level input voltage	$V_{IH}$	SDA, SCL	$0.7V_{DD}$		$V_{DD}$	V
Low-level input voltage	$V_{IL}$	SDA, SCL	0		$0.3V_{DD}$	V
High-level input leakage current	$I_{LH}$	SDA, SCL ( $V_{IN}=V_{DD}$ )			1.0	μA
Low-level input leakage current	$I_{LL}$	SDA, SCL ( $V_{IN}=0V$ )			250.0	μA
Low-level output voltage	$V_{OL}$	SDA,SCL=Low output, 5mA	0		0.6	V

\*1: SCL is an output during clock stretching.

## 8.2. AC Characteristics

### 8.2.1. Start/Stop Condition Bit Timing

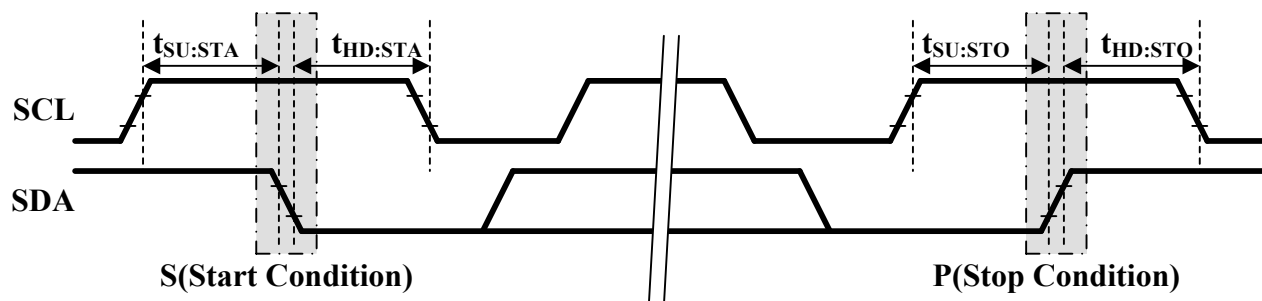

(Reference circuit under recommended operating conditions, unless otherwise noted)

Parameter	Symbol	Conditions	MIN	TYP	MAX	Unit
Start condition setup time	$t_{SU:STA}$	SCL, SDA pins	600			ns
Start condition hold time	$t_{HD:STA}$	SCL, SDA pins	600			ns
Stop condition setup time	$t_{SU:STO}$	SCL, SDA pins	600			ns
Stop condition hold time	$t_{HD:STO}$	SCL, SDA pins	600			ns

## 8.2.2. Bus Data Timing

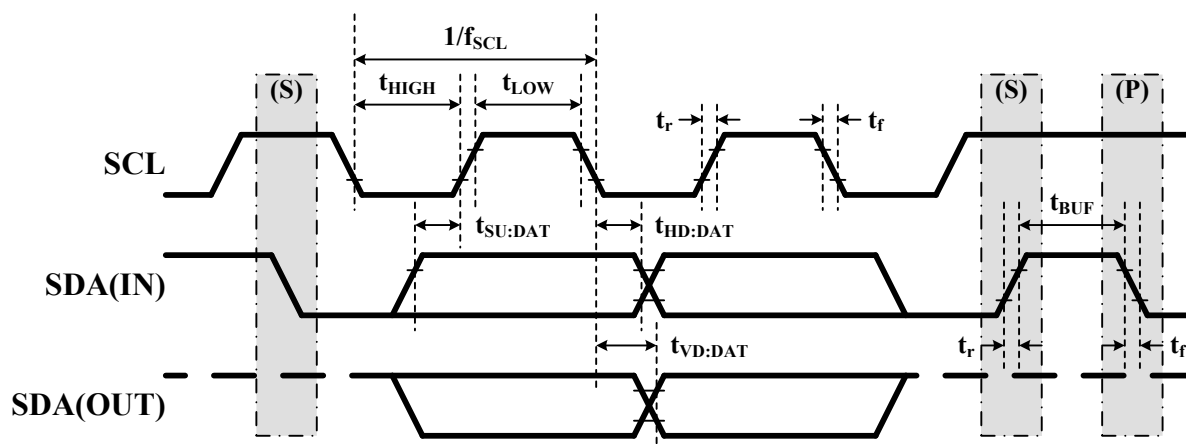

(Reference circuit under recommended operating conditions, unless otherwise noted)

Parameter	Symbol	Conditions	MIN	TYP	MAX	Unit
SCL clock frequency	$f_{SCL}$				400	kHz
SCL clock low-level cycle time	$t_{LOW}$		1300			ns
SCL clock high-level cycle time	$t_{HIGH}$		600			ns
SCL, SDA rise time 1	$t_{r1}$	$f_{CLS} > 100\text{kHz}$	$20+0.1 \times C_B$		300	ns
SCL, SDA rise time 2	$t_{r2}$	$f_{CLS} \leq 100\text{kHz}$			1000	ns
SCL, SDA fall time	$t_f$		$20+0.1 \times C_B$		300	ns
SCL, SDA data setup time 1	$t_{SU1:DAT}$	$f_{CLS} > 100\text{kHz}$	100			ns
SCL, SDA data setup time 2	$t_{SU2:DAT}$	$f_{CLS} \leq 100\text{kHz}$	250			ns
SCL, SDA data hold time	$t_{HD:DAT}$	Data input	0		900	ns
SCL, SDA data valid time	$t_{VD:DAT}$	Data output			900	ns
SCL, SDA bus capacitance	$C_B$				400	pF

## 8.3. Temperature Conversion Characteristics

- (1) Emission temperature accuracy: Typ.  $\pm 3.0^\circ$   
 (2) Emission temperature resolution: Typ.  $\pm 1.5^\circ$

Measured in NPC measurement environment of  $50^\circ\text{C}$  black body temperature and approximately  $25^\circ\text{C}$  ambient temperature, with field of view (FOV) of all sensor elements irradiated by infrared rays from the black body.

Note) The temperature conversion characteristics are affected by power supply noise, changes in temperature due to convection of the air, and temperature distribution across the target object. Accordingly, thorough evaluation should be conducted in the usage environment.

9. FUNCTIONAL DESCRIPTION

9.1. I<sup>2</sup>C Interface

Writing and reading configuration data is performed using an I<sup>2</sup>C interface. The device has a unique 7-bit address (slave address), and specifying the address is required. Configuration data is in MSB-first, 8-bit format.

9.1.1. Start/Stop Conditions

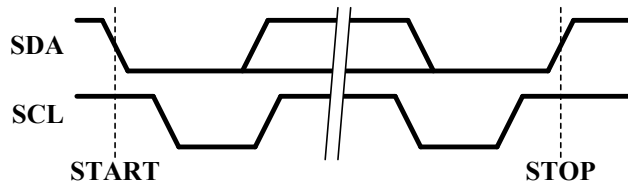

Figure 9-1-1-1. Start/Stop conditions

The Start condition occurs when SCL is High and SDA goes High→Low. Next, data is sent and received by the level transitions on SDA while SCL is Low.

The Stop condition occurs when SCL is High and SDA goes Low→High, and the basic communication cycle ends.

To change slave address or read/write mode during communication, you can set SDA from High→Low when SCL is High (Start condition) to restart the cycle in the same way.

9.1.2. Basic Cycle

[[Command write cycle]

The basic write cycle starts with the Start condition, followed by the 7-bit address and write (W) bit. Then a command is sent and data is written to the device

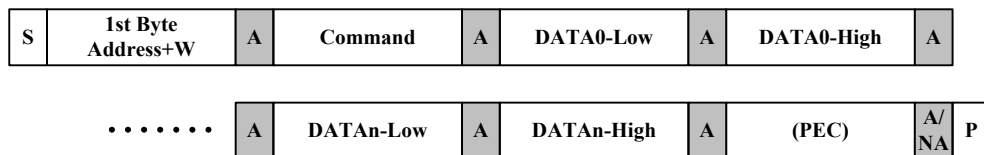

Figure 9-1-2-1. Command write cycle diagram

[Command read cycle]

The basic read cycle is the same as the write cycle above up to the command, followed by the Start condition again. Then, the 7-bit address and read (R) bit is sent, and then the data is read out.

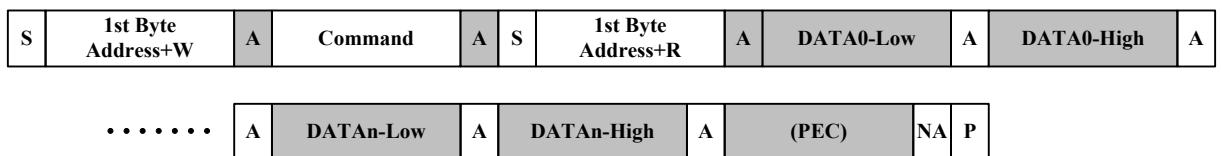

Figure 9-1-2-2. Command read cycle diagram

- \* In the diagrams above, the white areas indicate the SDA pin as in input, and the gray areas indicate the SDA pin as an output.
- \* The first bit after each 8-bit data is an acknowledge (ACK) bit. The receiver sets the ACK bit Low output (“A”) to indicate it is ready to receive. The receiver sets the ACK bit High output (“NA” = No ACK) when it is not ready to receive.

**9.1.3. Clock stretching and wait time after power on**

- (1) Clock stretching  
Clock stretching pauses a transaction by holding the SCL line Low.
- (2) Wait time from power on  
After the power is applied, the I<sup>2</sup>C I/F is able to start after 150ms have elapsed.  
It takes a further 250ms until the data of the first frame has stabilized.  
Accordingly, it takes 400ms after power is applied to obtain valid IR data (temperature/voltage) output.

**9.1.4. 1st Byte Data**

The first byte of data after the Start condition comprises the address and the read/write bit.

Bit7	Bit6	Bit5	Bit4	Bit3	Bit2	Bit1	Bit0
AD7	AD6	AD5	AD4	AD3	AD2	AD1	R/W

- (1) This device uses the following address.  
AD(7:1)      0001-010B: Configuration and data read out  
                  1010-0xxB: (Reserved)
- (2) Read/Write  
R/W            1: Data read   0: Data write

**9.1.5. Command Data**

- (1) Command = 00h   Write Only  
Data bytes: None  
Stop operation:            Stops temperature measurement operation.  
\* In one-shot mode, temperature measurement stops automatically after 1 frame measurement, without needing this command.
- (2) Command= 01h   Write Only  
Data bytes: None  
Start operation:            Starts temperature measurement operation.
- (3) Command=02h   Read Only  
Data bytes: 128 bytes (2×64 elements)  
Read the infrared output data (temperature/voltage).  
Voltage is in mV units. Temperature output is 10 times the Celsius value, expressed in 2s complement format.  
  
If the sensor output amplitude exceeds the maximum value that can be converted by the A/D converter, a value of -10000 (D8F0h) is output.
- (4) Command= 03h   Read Only  
Data bytes: 2 bytes  
Read the ambient temperature output data (temperature/voltage).  
Voltage is in mV units. Temperature output is 10 times the Celsius value, expressed in 2s complement format.

(5) Command=F0h Read/Write

Data bytes: 1 byte

Specify the element read order. Sets the read order (1 to 64) of the sensor elements.

TP\_READ\_ORDER

Bit [7:3]: Tied to 0 (Reserved).

Bit 2: Exchanges the vertical and horizontal directions.

0: Read elements from vertical direction to horizontal direction.

1: Read elements from horizontal direction to vertical direction.

Bit 1: Reverses the read order in the horizontal direction.

0: Natural order (TP8, TP16 ... TP64 rows)

1: Reverse order (TP64, TP56 ... TP8 rows)

Bit 0: Reverses the read order in the vertical direction.

0: Natural order (TP1, TP2 ... TP8 columns)

1: Reverse order (TP8, TP7 ... TP1 columns)

\* If all 3 bits are set to “1”, it first reverses the horizontal direction and vertical direction, and then it exchanges the vertical and the horizontal direction.

(F0h)=00h: Normal output

(F0h)=01h: Output with top/bottom reversed

(F0h)=02h: Output with left/right reversed

(F0h)=03h: Output with 180° rotation

(F0h)=04h: Output with image reflected across TP1 and TP64 diagonal axis

(F0h)=05h: Output with 90°counterclockwise rotation

(F0h)=06h: Output with 90°clockwise rotation

(F0h)=07h: Output with image reflected across TP8 and TP57 diagonal axis

(6) Command=F1h Read/Write

Data bytes: 1 byte

Specify amplifier gain. 0=200, 1=500, 2=700, 3=1000

4=1200, 5=1500, 6=1700, 7=2000

The default value is 7 (gain of 2000).

(7) Command=F2h Read/Write

Data bytes: 2 bytes

Specify emission adjustment value: Sets correction value with fixed decimal point 1 bit below MSB (0.00003 to 1.99997).

Positive values only.

During emission temperature conversion, the object's energy coefficient is used as-is in the multiplication.

The default value is 1(8000h).

(8) Command=F7h Read/Write

Data bytes: Current state 1 byte only

Read: Status read

Bit 7: Monitor operation.

1: Measuring

0: Stopped

Bit 6: Infrared output format.

1: Voltage

0: Temperature

Bit 5: Ambient temperature output format

1: Voltage

0: Temperature

Bit 4: Gain setting

1: Auto adjust

0: Set manually

Bit 3: PEC code

1: Enable

0: Disable

Bit 2: (Reserved: Default is 0)

Bit [1:0]: Frame rate

0=(Off), 1=1fps, 2=2fps, 3=4fps

Write: Configuration data

Bit 7: Operating mode	<u>1: Continuous</u>	0: One-shot mode
Bit 6: Infrared output format	1: Voltage	<u>0: Temperature</u>
Bit 5: Ambient temperature output format	1: Voltage	<u>0: Temperature</u>
Bit 4: Gain setting	1: Auto adjust	<u>0: Set manually</u>
Bit 3: PEC code	<u>1: Enable</u>	0: Disable
Bit 2: (Reserved: Default is 0)		
Bit [1:0]: Frame rate	0=(No change), 1=1fps, <u>2=2fps</u> , 3=4fps	

\* Default value is 8Ah (settings underlined above).

### 9.1.6. PEC Code

If the PEC code bit of configuration data is enabled,

Polynomial generation (CRC8): Adds remainder derived from  $G(x)=x^8+x^2+x^1+x^0$  to the output data from the module for error detection.

It does not perform error checking for input data to the module.

### 9.1.7. Automatic Gain Adjustment Function

The gain is adjusted automatically when bit 4 of the Configuration Data (Command= 0F7h) is set to "1".

- (1) When power is applied initially, the maximum gain of 2000 is set by default.
- (2) If the output from any sensor element exceeds the maximum level of the internal A/D converter during measurement, the gain is initially switched to the minimum gain of 200.
- (3) During measurement of the subsequent frame, the reference level is set to approximately half the maximum level of the A/D converter. If the measurement values of all sensor elements do not exceed the reference value, the range is increased one step at a time.  
(Gain of 200 → 500 → 700 → 1000 → 1200 → 1500 → 1700 → 2000)

The increase in range stops when at least one sensor element exceeds the reference level AND all elements do not exceed the maximum level at the current range setting.

If the output exceeds the maximum level during range switching, the gain is reduced to the minimum gain of 200 in a single action (the gain is not reduced one step at a time).

When bit 4 of the Configuration Data (Command= 0F7h) is set to "0", the gain is fixed and the gain setting switches to manual adjustment mode.

**10. ELEMENT ARRAY and FIELD-OF-VIEW IMAGE**

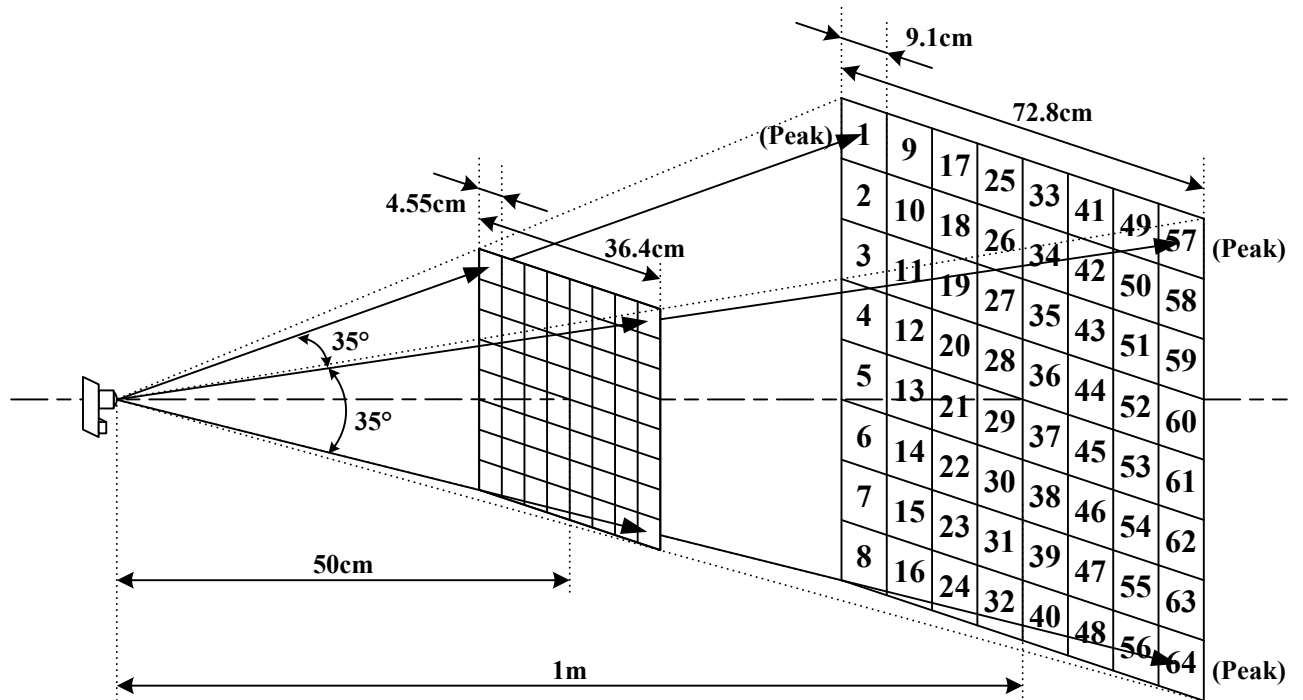
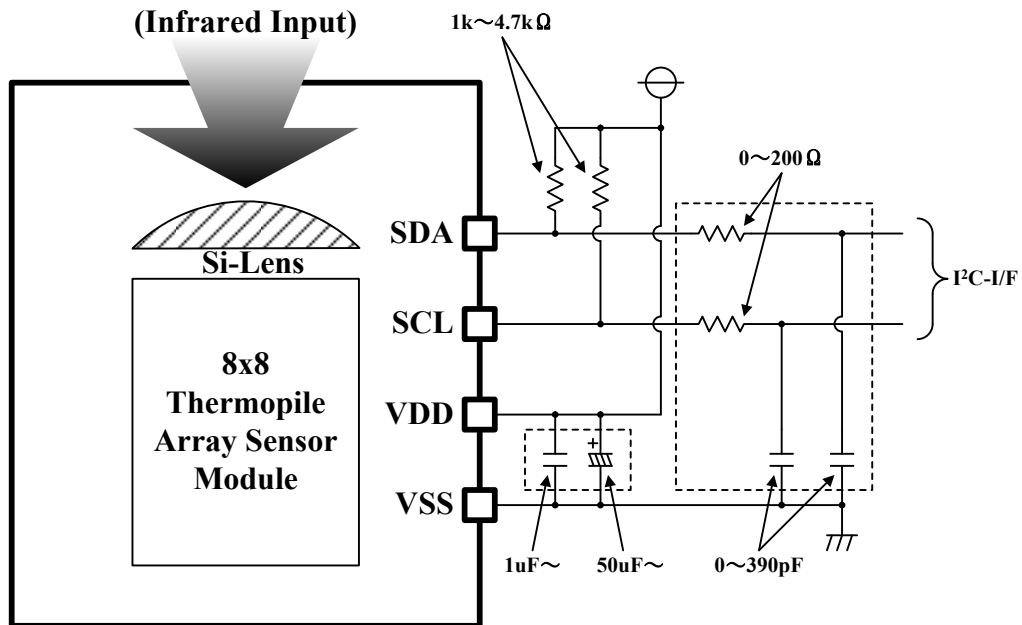

Figure 10-1. Field-of-view image diagram

## 11. TYPICAL APPLICATION CIRCUIT



(Components within dotted lines included/excluded and adjusted to suit the noise environment.)

Figure 11-1. Typical application circuit

- \* This typical application circuit is provided for reference only, and does not represent a circuit with guaranteed operation. NPC will not be held liable for any loss due to the use of this circuit. Always conduct a thorough evaluation before use.

## 12. DIMENSIONS

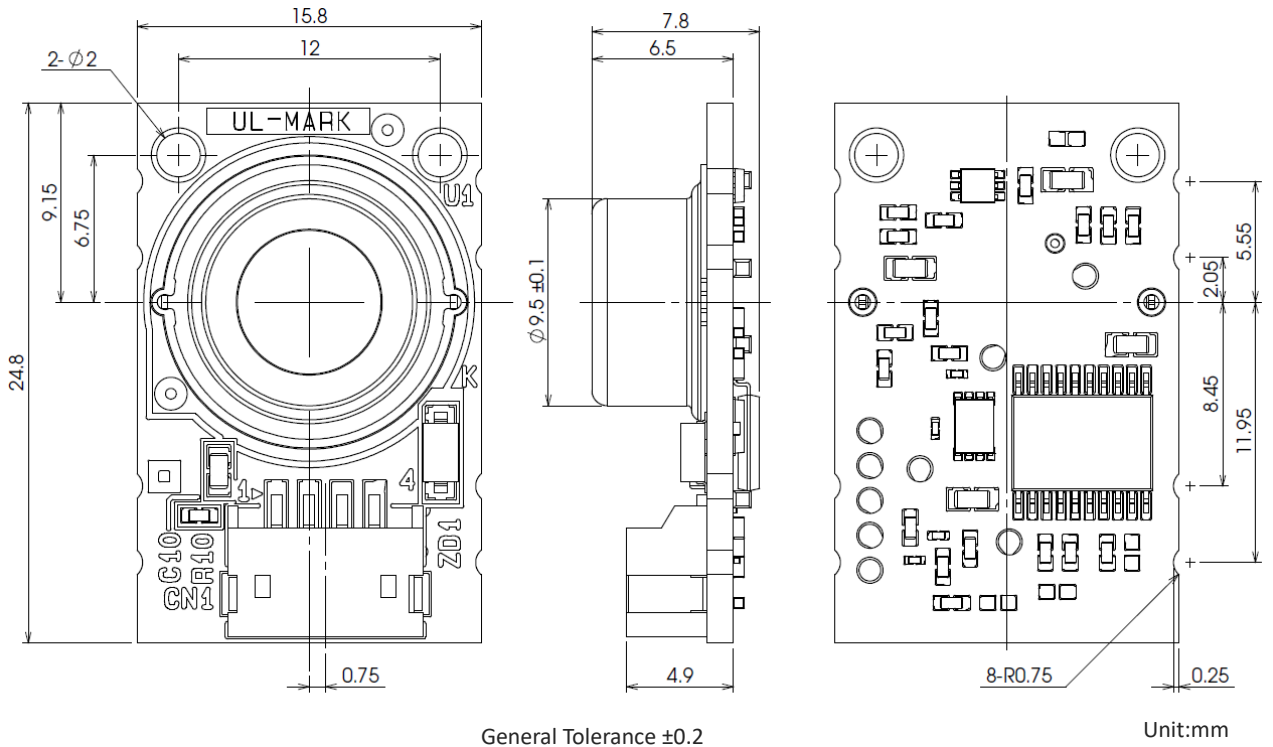

Figure 12-1. External dimensions

**13. PRECAUTIONS FOR USE****13.1. Safety Precautions**

Observe the following precautions at all times to prevent an accident.

- Do not exceed the ratings, environmental conditions, and other specifications ranges.
- Connect terminal connections correctly after checking the terminal locations.
- The sensor module has several failure modes, including short-circuit between terminals, open-circuit terminals, device temperature rise (for example, due to power supply short-circuit), temperature output error, and I/F communications error. In applications requiring a high degree of reliability, take scrupulous care and apply fail-safe techniques, including adding redundancy and malfunction prevention.
- Do not dismantle and reassemble the sensor module.
- The execution of commands not described in this specifications document may cause a malfunction or deterioration in performance.

**13.2. Notes about Device Principles**

An infrared array sensor is a sensor for detecting the level of infrared radiation, not a direct measurement of the temperature. The emission temperature of an object within the viewing angle is determined based on the detected infrared energy. In addition, the temperature determination may also be significantly affected by changes in temperature of the module itself.

Before use, always conduct a thorough evaluation under actual conditions to check device operation.

In particular, the temperature determination may be adversely affected in the following cases.

- When the sensor and measurement object are extremely close to any surrounding objects that have a temperature difference.
- When the emissivity of the measurement object is low and the impact of reflections from other objects is high.
- When the measurement object is made of a material that exhibits variations in emissivity due to the angle facing the sensor, for example.
- When strong infrared sources, such as direct sunlight or flames, are scattered into the sensor.
- When the uniformity of the surrounding environment temperature is affected, such as when a breeze of different temperature to the sensor lens barrel hits the back of the sensor substrate.
- When the sensor body temperature is changing.
- When a material which does not pass far-infrared adheres to the sensor lens.  
(If a foreign substance adheres to the sensor lens, gently wipe it off using a soft cloth or a cloth moistened with alcohol.)

**13.3. Precautions on Usage Environment**

Note that use in the following cases may lead to a deterioration in performance.

- When the lens or the lens barrel is subjected to strong vibration or strong impact.
- When the sensor is used in a corrosive gas environment.
- When the sensor is stored or used in a high-temperature, high-humidity environment over a long term period.
- When dew condensation or freezing occurs.
- When submerged in water or covered in dust.  
(Take appropriate waterproof and dustproof countermeasures.)

**13.4. Precautions during Assembly and Installation**

- This product uses a S4B-ZR-SM4A-TF connector (JST Mfg. Co., Ltd.).  
Use compatible wiring contacts (SZH-002T-P0.5 or SZH-003T-P0.5) and housing (ZHR-4).
- Insert and remove the connector under normal temperature (5°C to 35°C) and condensation-free conditions.
- Insert and remove the connector with the power disconnected.
- Do not apply excessive mechanical force when inserting/removing the connector.
- This connector is used for the internal wiring of devices, and is not to be used for any external wiring.  
Precautions should be taken to ensure that regular users cannot touch the connector or wiring.
- Leave slack in the wiring so that no tension is exerted on the connector.
- Secure in position so that there is no excessive force applied to the board or lens barrel.
- Take care not to connect the power supply in the reverse orientation. Doing so may cause failure or a deterioration in performance.
- Take measures against electrostatic discharge during device assembly. Electrostatic discharge may cause device failure.

**13.5. Precautions for Use in Target Devices**

This product is designed and manufactured to the generally accepted standards of reliability as expected for use in general electronic and electrical equipment, such as personal equipment, machine tools, and measurement equipment. This product is not designed and manufactured to be used in any other special equipment requiring extremely high level of reliability and safety, such as aerospace equipment, nuclear power control equipment, medical equipment, transportation equipment, disaster prevention equipment, or security equipment.

If you wish to use this product in equipment requiring an extremely high level of reliability, please contact our sales department or representative in advance.

In the event that this product is used in such equipment, please take scrupulous care and apply fail-safe techniques, including redundancy and malfunction prevention, in order to prevent damage to life, health, property, or infrastructure etc. in case there is some malfunction in the product.

Please pay your attention to the following points at time of using the products shown in this document.

1. The products shown in this document (hereinafter "Products") are designed and manufactured to the generally accepted standards of reliability as expected for use in general electronic and electrical equipment, such as personal equipment, machine tools and measurement equipment. The Products are not designed and manufactured to be used in any other special equipment requiring extremely high level of reliability and safety, such as aerospace equipment, nuclear power control equipment, medical equipment, transportation equipment, disaster prevention equipment, security equipment. The Products are not designed and manufactured to be used for the apparatus that exerts harmful influence on the human lives due to the defects, failure or malfunction of the Products.

If you wish to use the Products in that apparatus, please contact our sales section in advance.

In the event that the Products are used in such apparatus without our prior approval, we assume no responsibility whatsoever for any damages resulting from the use of that apparatus.

2. NPC reserves the right to change the specifications of the Products in order to improve the characteristics or reliability thereof.
3. The information described in this document is presented only as a guide for using the Products. No responsibility is assumed by us for any infringements of patents or other rights of the third parties which may result from its use. No license is granted by implication or otherwise under any patents or other rights of the third parties. Then, we assume no responsibility whatsoever for any damages resulting from that infringements.
4. The constant of each circuit shown in this document is described as an example, and it is not guaranteed about its value of the mass production products.
5. In the case of that the Products in this document falls under the foreign exchange and foreign trade control law or other applicable laws and regulations, approval of the export to be based on those laws and regulations are necessary. Customers are requested appropriately take steps to obtain required permissions or approvals from appropriate government agencies.
6. When exporting customer's products that use the Products, customers must comply with the "Foreign Exchange and Foreign Trade Act" and other export-related laws and regulations, and follow the necessary procedures in accordance with those laws and regulations. Do not use the Products in equipment whose sale is prohibited by export-related laws and regulations ("JP Foreign Exchange and Foreign Trade Act" and "US Export Administration Regulations", etc.). In addition, please do not sell the Products to users who are expected to use it for the above equipment or companies in its supply chain. If a user who uses module parts and equipment using the Products is a company suspected of violating human rights, please do not sell the above parts and equipment to that user.

**SEIKO NPC CORPORATION**

2-9-4, Taito, Taito-ku,  
Tokyo 110-0016, Japan  
Telephone: +81-3-6747-5301  
Facsimile: +81-3-6747-5303  
<http://www.npc.co.jp/>  
Email: [sales@npc.co.jp](mailto:sales@npc.co.jp)