

1. OVERVIEW

The SMD-01B is a high-precision optical encoder IC that employs a diffraction image projection method. It incorporates an OEIC (Opto-Electric Integrated Circuit) and LED light source in a single package. Light emitted from the LED is projected onto a scale, and the reflected diffraction image is focused on a photodiode. The reflected light contains position information that is recovered to detect the relative movement between the SMD-01B and the scale. A photodiode array is used to reduce degradation in phase characteristics due to mounting alignment. This allows the SMD-01B to be mounted without monitoring the output signal, unlike conventional high-precision optical encoders which typically need to be mounted and aligned while monitoring the output signal.

2. FEATURES

- Package: Miniature clear-mold package (5.3mm × 4.3mm × 1.68mm)
- Resolution: 5μm (using 20μm pitch pattern scale and A-phase/B-phase signal detection)
- Optimized OEIC and optics design for easy mounting alignment
- LED and OEIC fabricated in a single package
- Adjustable LED brightness using external inputs
- Analog (sine wave) output
- Supply voltage: 3.13 to 5.25V
- Current consumption: 12.2 mA

3. APPLICATIONS

- Precision stages
- Sliders
- Robots

4. BLOCK DIAGRAM

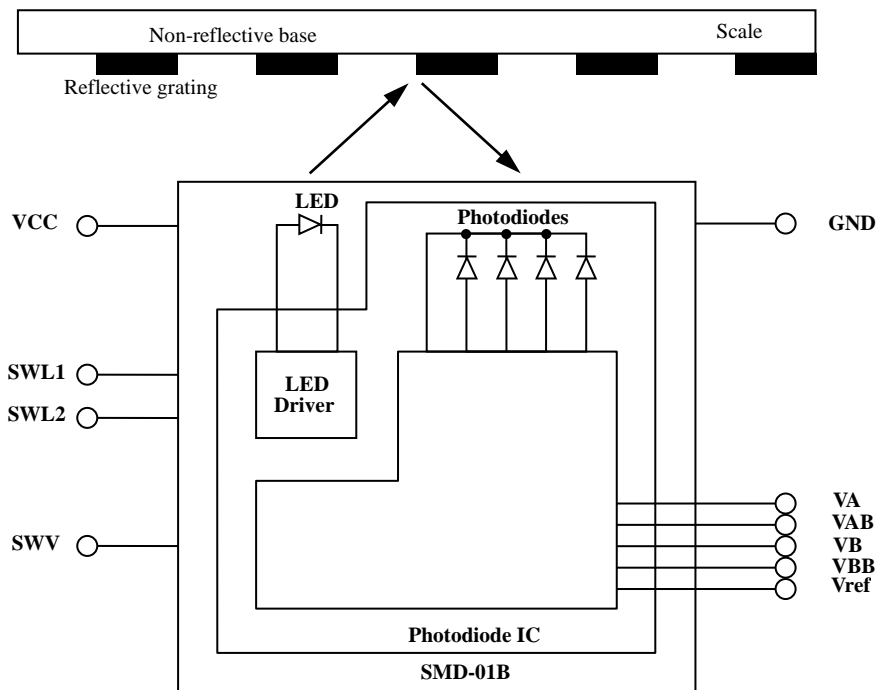

5. PIN LAYOUT

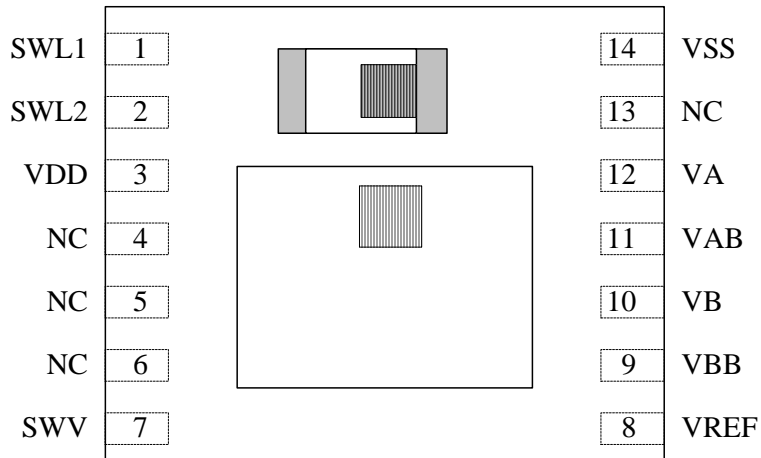

6. PIN DESCRIPTION

Number	Name	I/O	Description
1	SWL1	I	LED brightness adjustment 1 (pull up)
2	SWL2	I	LED brightness adjustment 2 (pull up)
3	VDD	-	Supply voltage
4	NC	-	No connection (leave open circuit)
5	NC	-	No connection (leave open circuit)
6	NC	-	No connection (leave open circuit)
7	SWV	I	Reference voltage select input (pull up)
8	VREF	O	Reference voltage output
9	VBB	O	B-phase inverted analog signal (BB phase) output
10	VB	O	B-phase analog signal (B phase) output
11	VAB	O	A-phase inverted analog signal (AB phase) output
12	VA	O	A-phase analog signal (A phase) output
13	NC	-	No connection (leave open circuit)
14	VSS	-	Ground

7. ABSOLUTE MAXIMUM RATINGS

V_{SS}=0V

Parameter	Symbol	Conditions	Rating	Unit	note
Supply voltage range	V _{DD}	Voltage between VDD and VSS	-0.3 to +6.0	V	*1
Input voltage range	V _{IN}	SWL1 , SWL2 , SWV pins	-0.3 to V _{DD} +0.3	V	*1, *2
Output voltage range	V _{OUT}	VA , VAB , VB , VBB , VREF pins	-0.3 to V _{DD} +0.3	V	*1, *2
Storage temperature range	T _{STG}	-	-40 to +80	°C	*3

*1: Absolute maximum ratings are the values that must never be exceeded, even for a moment. This product may suffer breakdown if any one of these parameter ratings is exceeded. Operation and characteristics are guaranteed only when the product is operated at recommended supply voltage range.

*2: V_{DD} is the V_{DD} value of recommended operating conditions.

*3: When stored alone in nitrogen or vacuum atmosphere.

8. RECOMMENDED OPERATING CONDITIONS

V_{SS}=0V

Parameter	Symbol	Conditions	MIN	TYP	MAX	Unit
Supply voltage	V _{DD}	Between VDD and VSS terminals SWV = H	3.13	3.3	5.25	V
		Between VDD and VSS terminals SWV = L or H	4.75	5	5.25	V
Operating temperature	T _a	-	-20	-	60	°C
Response speed	R _t	-	0	-	2	m/s

* Since it may influence the reliability if it is used out of the recommended operating conditions range, this product should be used within this range.

9. ELECTRICAL CHARACTERISTICS

9.1. DC Characteristics

$V_{DD} = 5V$, $V_{SS} = 0V$, $T_a = 27^\circ C$ unless otherwise noted

Parameter	Symbol	Conditions	MIN	TYP	MAX	Unit	Pins
Current consumption 1	I_{DD1}	SWL1 = H , SWL2 = H	4	12.2	23	mA	VDD
Current consumption 2	I_{DD2}	SWL1 = H , SWL2 = L	7	16.9	30		
Current consumption 3	I_{DD3}	SWL1 = L , SWL2 = H	11	21.0	35.5		
Current consumption 4	I_{DD4}	SWL1 = L , SWL2 = L	2	6	13.5		
Reference voltage 1	V_{ref1}	SWV=H	1	1.45	2	V	VREF
Reference voltage 2	V_{ref2}	SWV=L $V_{DD} = 5 \pm 0.25V$	1.4	2.25	3.2		
A-phase signal offset voltage	V_{AO}	SWL1 = L , SWL2 = L Variation from VREF	-0.25	-	0.25	V	VA
AB-phase signal offset voltage	V_{ABO}						VAB
B-phase signal offset voltage	V_{BO}						VB
BB-phase signal offset voltage	V_{BBO}						VBB
Output voltage fluctuation 1	ΔV_{O1}	Difference between 0 μ A and 50 μ A sink current	0	-	30	mV	VREF VA VAB VB VBB
Output voltage fluctuation 2	ΔV_{O2}	Difference between 0 μ A and 50 μ A source current	-30	-	0		
HIGH-level input voltage	V_{IH}	-	$0.8 * V_{DD}$	-	V_{DD}	V	SWL1 SWL2 SWV
LOW-level input voltage	V_{IL}	-	0	-	$0.2 * V_{DD}$	V	
HIGH-level input current	I_{IH}	$V_{IN} = V_{DD}$	-1	-	1	μ A	
LOW-level input current	I_{IL}	$V_{IN} = V_{SS}$	-20	-	-1	μ A	

9.2. Analog Characteristics

$V_{DD} = 5V$, $V_{SS} = 0V$, $T_a = 27^\circ C$ unless otherwise noted

Parameter	Symbol	Conditions	MIN	TYP	MAX	Unit	Pins
A-phase output signal amplitude	V_{AP-P}	SWL1 = H , SWL2 = H Standard scale conditions Value of peak to peak	0.13	0.85	3	V	VA
AB-phase output signal amplitude	V_{ABP-P}						VAB
B-phase output signal amplitude	V_{BP-P}						VB
BB-phase output signal amplitude	V_{BBP-P}						VBB
A-phase - B-phase difference	D_p	Standard scale conditions	50	90	130	°	VA,VB

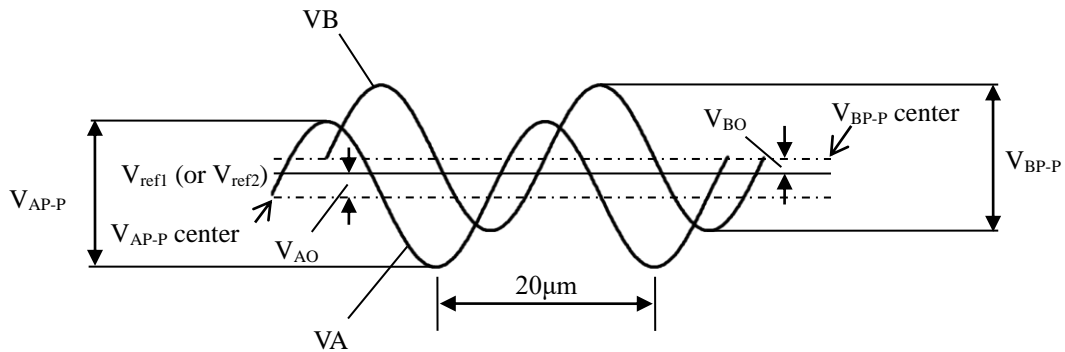

V_{AO} & V_{BO} offsets represent the differences between the VA & VB cycle center lines and V_{ref1} (or V_{ref2}).

9.3. Standard Scale Conditions

Electrical characteristics ratings apply under the following conditions.

Parameter		Conditions	Unit
Scale	Reflective surface reflection factor	57	%
	Non-reflective surface reflection factor	5	%
	Pattern	20μm pitch (10μm Cr line/10μm spacing)	-
Mounting	Gap (ΔGap)	0.3	mm
	Yaw angle ($\Delta\theta_y$) Roll angle ($\Delta\theta_r$) Pitch angle ($\Delta\theta_p$)	0	°

10. FUNCTIONAL DESCRIPTION

The SMD-01B IC emits 632nm center-wavelength visible light from the LED and projects the light through a slit and onto a scale having a 20 μ m pitch (10 μ m lines/10 μ m spacing) grating pattern. The reflected diffraction image is focused on a photodiode array to detect the relative movement between the IC and the scale. An analog signal (sine wave) with a cycle period of 20 μ m is output. The output signal is composed by the 90° phase difference A-phase and B-phase diffraction signals.

10.1. LED Brightness Switching Function

The signal amplitude can be adjusted by adjusting the LED brightness. The LED brightness is adjusted by adjusting the LED current. The amplitude adjustment options are shown in the following table.

SWL1	H	H	L	L
SWL2	H	L	H	L
A/B-phase analog signal amplitude	$\times 1.0$	$\times 1.8$	$\times 2.6$	$\times 0$

10.2. Reference Voltage Switching Function

The SMD-01B has a function for switching the reference voltage (Vref) by changing the setting of the SWV pin. Set the reference voltage according to the required input conditions of the following stage circuit.

11. SCALE Mounting Conditions

The optical center position of encoder ic is offset from the physical center of the ic by 0.77mm (ΔY) in the vertical direction and 0.0mm (ΔX) in the horizontal direction. If using a linear scale, only the offset in the scale width direction (ΔY) needs to be considered. If using a rotary scale, the scale offset in the horizontal direction (ΔX) must also be taken into account.

Conditions of optimum optics of this product may vary due to mounting tolerance of optical elements, so thorough evaluation is needed to set the conditions. Particularly when using small-diameter rotary scale, effect of alignment conditions on signal amplitude and phase difference is greater than when using linear scale. Individualized alignment is recommended to obtain better product characteristics.

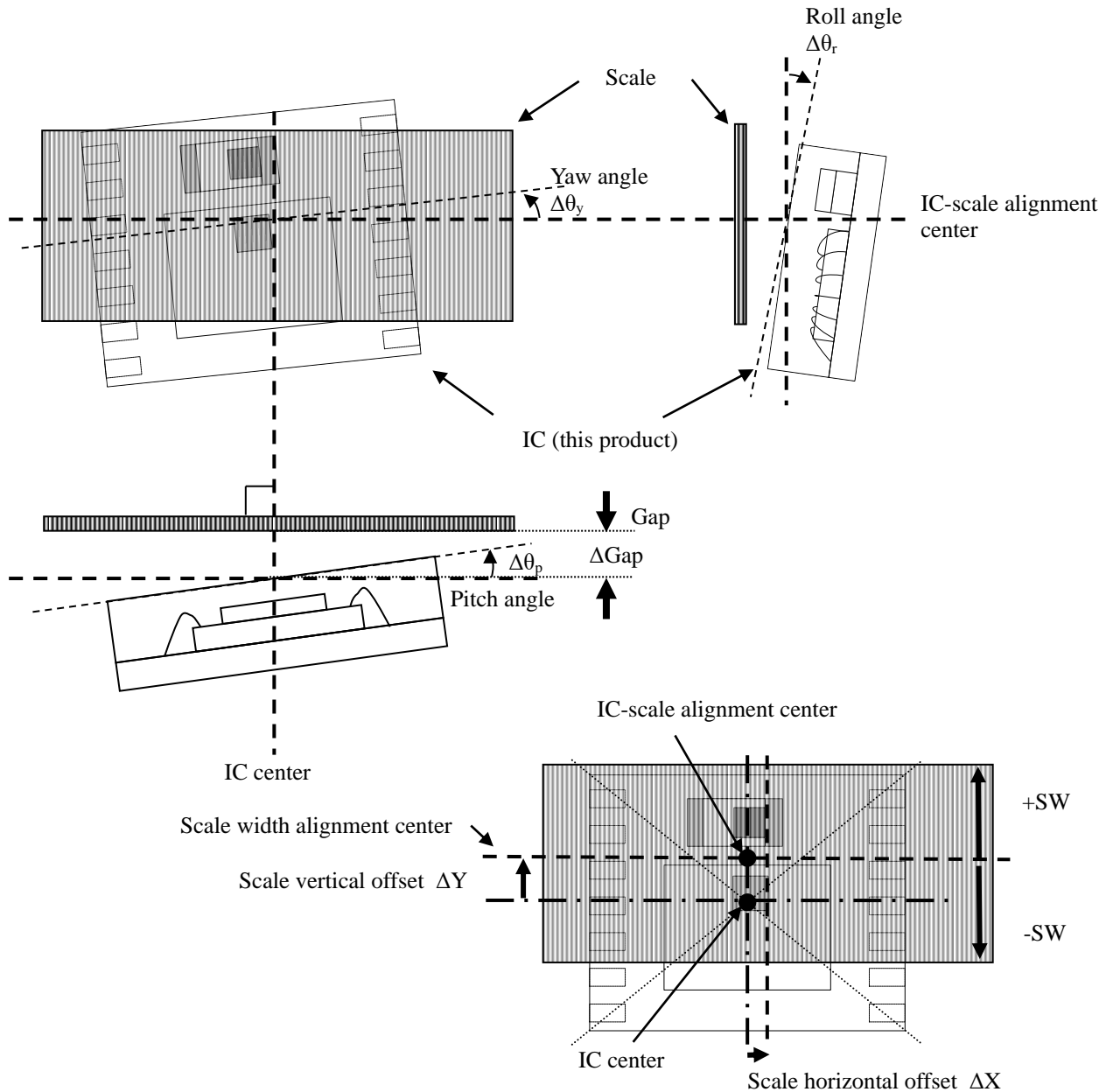

Reference data:

	Parameter	Conditions	Unit
Scale	Scale width ($\pm SW$)	± 1 (min)	mm
Mounting	Scale vertical offset (ΔY)	0.77	mm
	Scale horizontal offset (ΔX)	0.0	mm

12. REFERENCE DATA

* NPC Standard Conditions Scale and IC Alignment

12.1. Alignment Characteristics

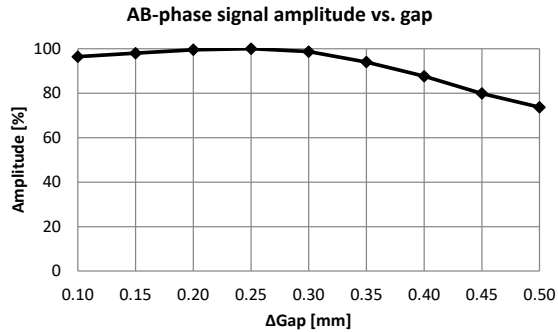

Amplitude vs. Gap (ΔGap)

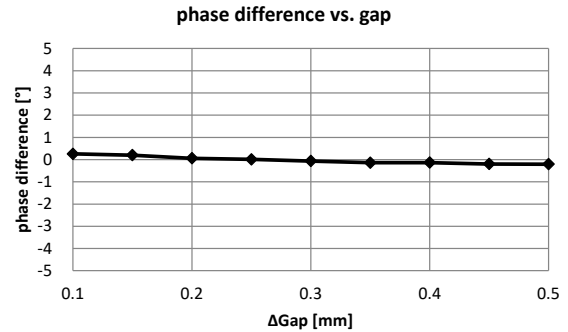

Phase difference vs. Gap (ΔGap)

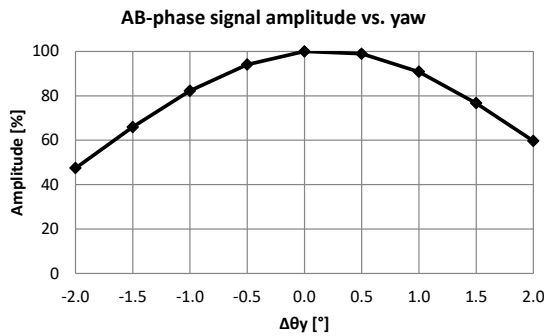

Amplitude vs. Yaw angle ($\Delta\theta_y$)

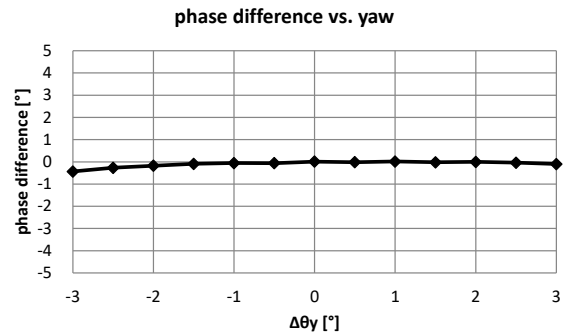

Phase difference vs. Yaw angle ($\Delta\theta_y$)

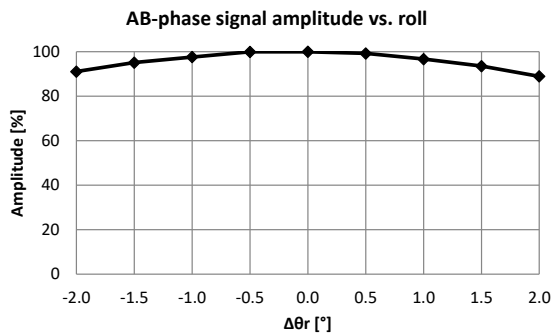

Amplitude vs. Roll angle ($\Delta\theta_r$)

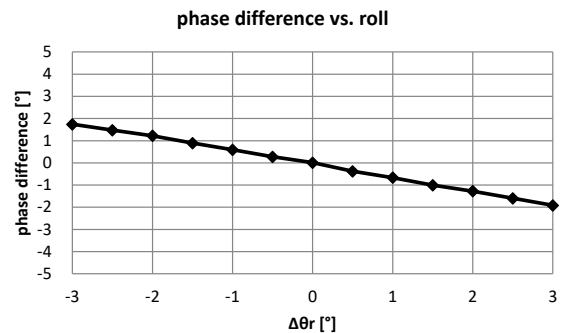

Phase difference vs. Roll angle ($\Delta\theta_r$)

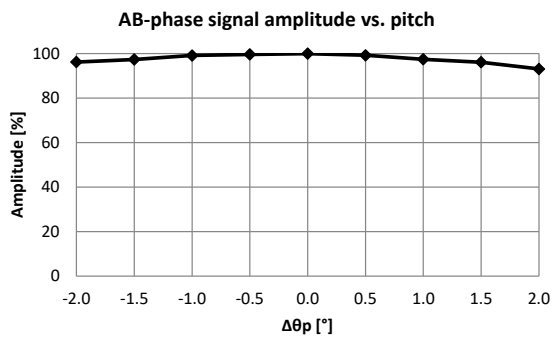

Amplitude vs. Pitch angle ($\Delta\theta_p$)

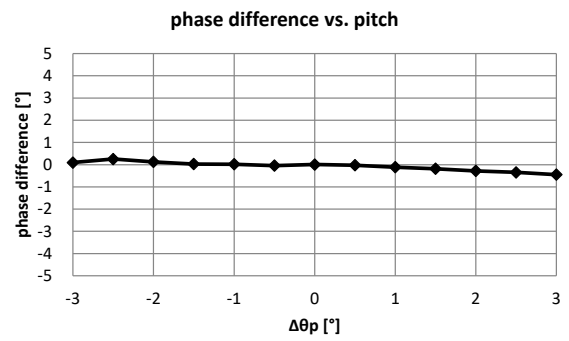

Phase difference vs. Pitch angle ($\Delta\theta_p$)

12.2. Temperature Characteristics

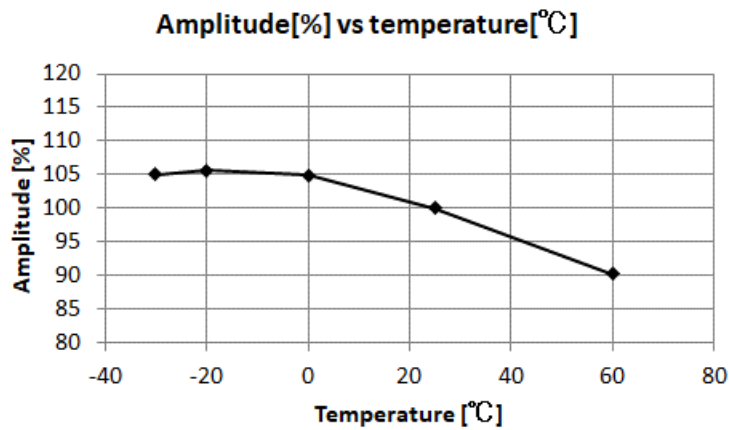

Amplitude vs. Temperature (T_a)

12.3. Frequency Characteristics

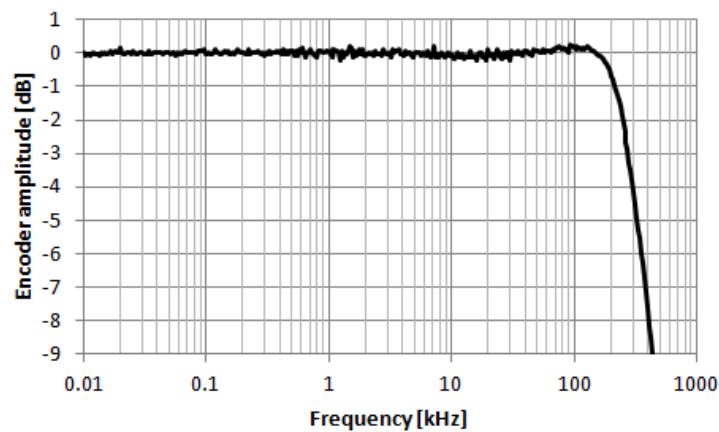

Amplitude vs. Frequency

13. PACKAGE DIMENSIONS

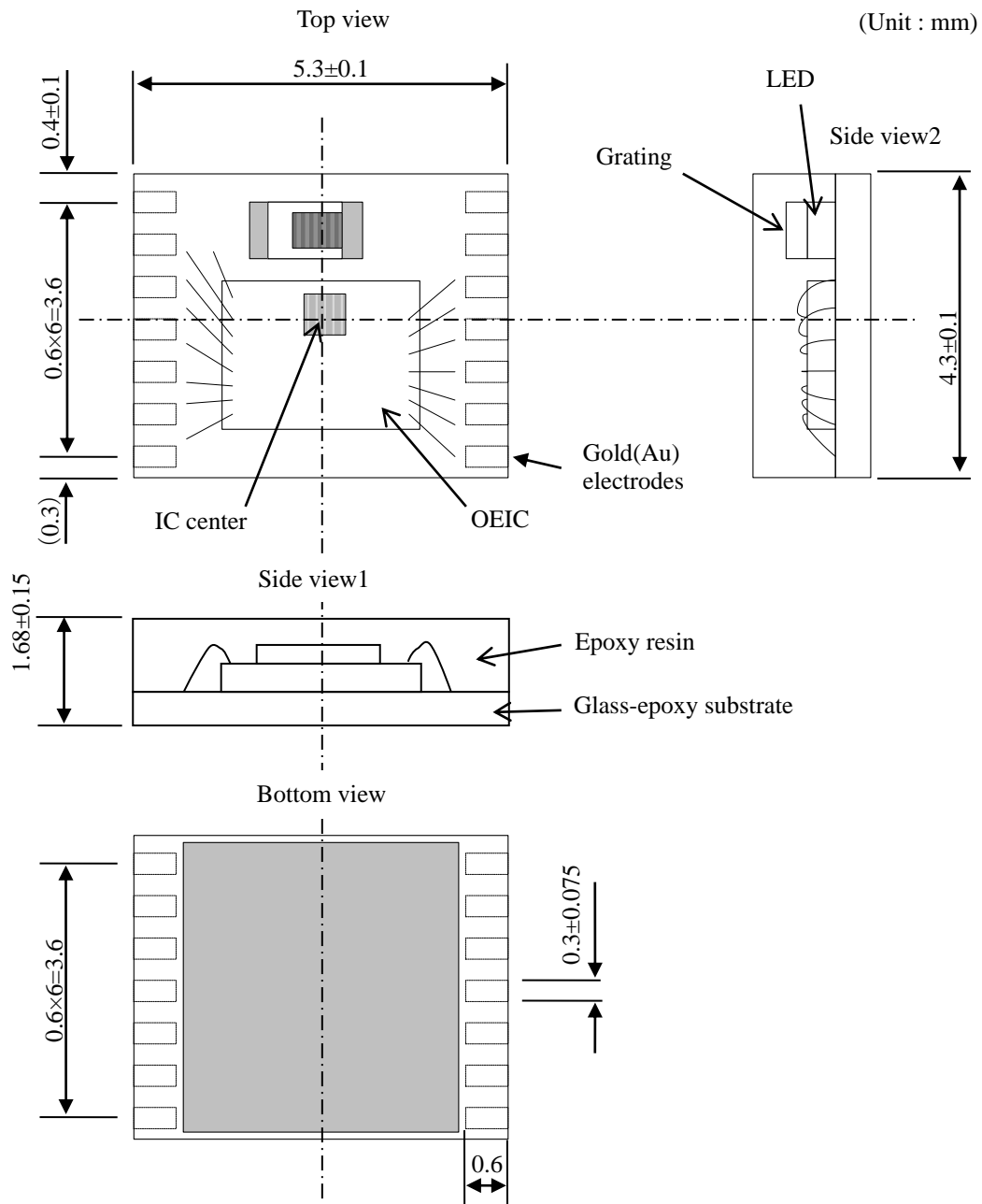

14. PRECAUTION FOR USE

Wire involved in drive actuator should be placed as far away from SMD-01B and wire drawn out from SMD-01B (especially analog signal wire) as possible.

The closer, the larger the noise to encoder ic signal. More digital signal chattering occur when the noise is larger, and position detection accuracy is deteriorated.

Capacitors shown below should be placed on VDD wire and VSS wire of SMD-01B for protection against noise.

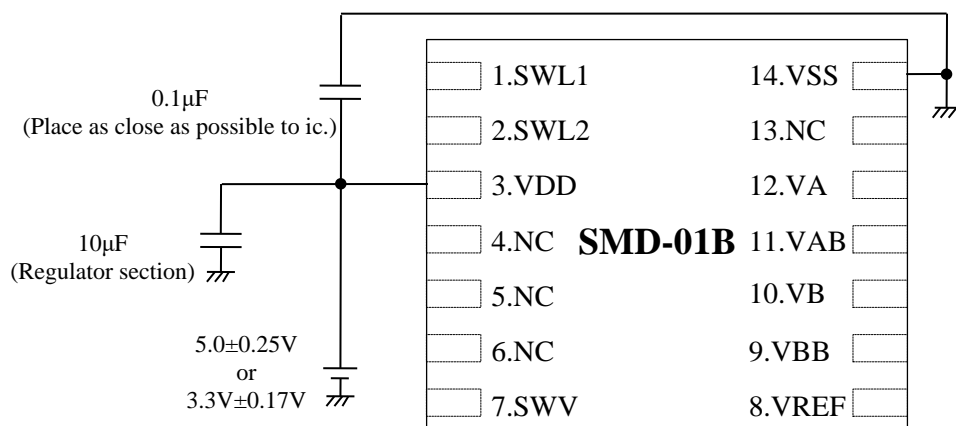

15. USAGE AND PRECAUTIONS

This product is designed and manufactured to the generally accepted standards of reliability as expected for use in general electronic and electrical equipment, such as personal equipment, machine tools, and measurement equipment. This product is not designed and manufactured to be used in any other special equipment requiring extremely high level of reliability and safety, such as aerospace equipment, nuclear power control equipment, medical equipment, transportation equipment, disaster prevention equipment, security equipment.

If you wish to use this product in equipment requiring extremely high level of reliability, please contact our sales department or representative in advance.

In the event that this product is used in such equipment, please take scrupulous care and apply fail-safe techniques including redundancy and malfunction prevention in order to prevent damage to life, health, property, or infrastructure etc. in case there is some malfunction in the product.

Please pay your attention to the following points at time of using the products shown in this document.

1. The products shown in this document (hereinafter "Products") are designed and manufactured to the generally accepted standards of reliability as expected for use in general electronic and electrical equipment, such as personal equipment, machine tools and measurement equipment. The Products are not designed and manufactured to be used in any other special equipment requiring extremely high level of reliability and safety, such as aerospace equipment, nuclear power control equipment, medical equipment, transportation equipment, disaster prevention equipment, security equipment. The Products are not designed and manufactured to be used for the apparatus that exerts harmful influence on the human lives due to the defects, failure or malfunction of the Products.
If you wish to use the Products in that apparatus, please contact our sales section in advance.
In the event that the Products are used in such apparatus without our prior approval, we assume no responsibility whatsoever for any damages resulting from the use of that apparatus.
2. NPC reserves the right to change the specifications of the Products in order to improve the characteristics or reliability thereof.
3. The information described in this document is presented only as a guide for using the Products. No responsibility is assumed by us for any infringements of patents or other rights of the third parties which may result from its use. No license is granted by implication or otherwise under any patents or other rights of the third parties. Then, we assume no responsibility whatsoever for any damages resulting from that infringements.
4. The constant of each circuit shown in this document is described as an example, and it is not guaranteed about its value of the mass production products.
5. In the case of that the Products in this document falls under the foreign exchange and foreign trade control law or other applicable laws and regulations, approval of the export to be based on those laws and regulations are necessary. Customers are requested appropriately take steps to obtain required permissions or approvals from appropriate government agencies.
6. When exporting customer's products that use the Products, customers must comply with the "Foreign Exchange and Foreign Trade Act" and other export-related laws and regulations, and follow the necessary procedures in accordance with those laws and regulations. Do not use the Products in equipment whose sale is prohibited by export-related laws and regulations ("JP Foreign Exchange and Foreign Trade Act" and "US Export Administration Regulations", etc.). In addition, please do not sell the Products to users who are expected to use it for the above equipment or companies in its supply chain. If a user who uses module parts and equipment using the Products is a company suspected of violating human rights, please do not sell the above parts and equipment to that user.

**SEIKO NPC CORPORATION**

2-9-4, Taito, Taito-ku,
Tokyo 110-0016, Japan
Telephone: +81-3-6747-5300
Facsimile: +81-3-6747-5303
<https://www.npc.co.jp/>
Email: sales@npc.co.jp